

- HIGH QUALITY
- FUNCTIONALITY
- STRENGTH



### Material

High-quality structural steel,  
anti-corrosion coating *Magnelis*

### Modules layout

Portrait, 2 rows

### System type

Ground mounted, double support,  
rammed into the ground

### Angle

30° (27° for K502 XL)



K500 Sp. z o.o.  
Górzna 113, 77-400 Górzna  
Warehouse  
ul. Sulechowska 4a, hala 25,  
65-119 Zielona Góra



biuro@k500.pl



+48 67 307 00 36



www. K500.pl

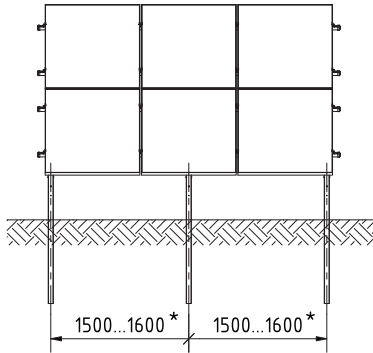

\* Depending on the PV modules width

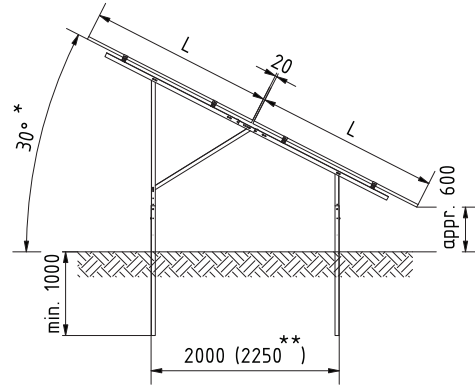

\* Or 27° for K502 XL

\*\* For K502 XL

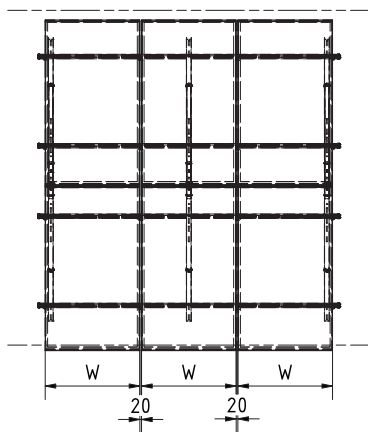

### MODULES DIMENSIONS

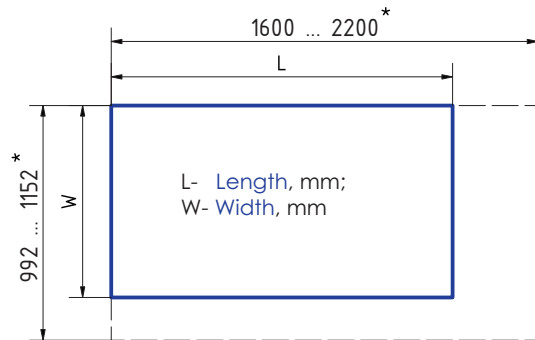

* K502	L 1600...1750; W 992...1052
K502 MAX	L 1600...2020; W 992...1152
K502 XL	L 2020...2200; W 1052...1152

### PARAMETERS

<b>Modules layout</b>	Portrait
<b>Per row</b>	2
<b>PV modules qty.</b>	max. 20
<b>Angle</b>	30° (27° for K502 XL)
<b>Foundation depth</b>	min 1000 mm
<b>Material</b>	High-quality structural steel with increased durability Magnelis

### ADDITIONAL OPTION

Inverter mounting set

GET TO KNOW THE DETAILS

